



# THE CONNECTICUT STATE UNIVERSITY

P.O. Box 2008 • New Britain, Connecticut 06050 • (203) 827-7700

## RESOLUTION

concerning

### RECLASSIFICATION OF POSITION

ASSOCIATE DEAN ACADEMIC AFFAIRS/ADMINISTRATOR VII  
to  
ASSISTANT VICE-PRESIDENT FOR ACADEMIC AFFAIRS

at

EASTERN CONNECTICUT STATE UNIVERSITY

JANUARY 16, 1987

RESOLVED, That the position, Associate Dean Academic Affairs/Administrator VII, at Eastern Connecticut State University, be reclassified to Assistant Vice-President for Academic Affairs, effective July 1, 1987, in accordance with all provisions and expectations as set forth in the proposal attached as an addendum to this resolution.

A Certified True Copy:

Dallas K. Beal  
President

CSU-200

EASTERN CONNECTICUT STATE UNIVERSITY

DATE 12/16/86

POSITION ACTION REQUEST

-----  
 POSITION DATE PERM(X) FT(X)  
 ACTION: ESTABLISH ( ) RECLASSIFY (X) EFF. 7/1/87 TEMP( ) PT( )  
 ABOLISH ( ) OTHER ( )

POSITION  
 TITLE Assoc. Dean Academic Affairs 7869 Assistant V.P. for Academic Affairs  
 CURRENT CLASS CODE PROPOSED CLASS CODE

POSITION	CURRENT	PROPOSED	BARG	UNIT	SUOAF	Unclass/Mgt
NUMBER <u>1851</u>	SALARY <u>2197.73</u> <u>57,360</u>	SALARY <u>1915.71</u> <u>50,000</u>			From	To
		FUND <u>Gen.</u>				

RESOLUTION

BR# \_\_\_\_\_

RESOLVED, That the present position, Associate Dean, Academic Affairs, be reclassified to Assistant Vice-President for Academic Affairs and reclassified from the SUOAF Bargaining Unit to Unclassified Management.

A Certified True Copy \_\_\_\_\_

Dallas K. Beal, President Date \_\_\_\_\_

PERCommittee 1/7/87  
Date \_\_\_\_\_

BOARD OF TRUSTEES 1/16/87  
Date \_\_\_\_\_

JUSTIFICATION:

As part of the reorganization of the Office of Academic Affairs, the Univ. wishes to assign various line responsibilities to the present Assoc. Dean position. The new incumbent will assume present responsibility in the existing job description in addition to line supervision of the Media Center, Learning Center, Advisory Center, and University Library.

EASTERN CONNECTICUT STATE UNIVERSITY  
POSITION DESCRIPTION

TITLE: ASSISTANT VICE-PRESIDENT FOR ACADEMIC AFFAIRS

RANK: UNCLASSIFIED MANAGEMENT (EQUIVALENT TO SALARY AND RANK OF  
DEAN)

OFFICE: ACADEMIC AFFAIRS

SUPERVISOR: VICE-PRESIDENT FOR ACADEMIC AFFAIRS

Under the supervision of the Vice-President for Academic Affairs, the Assistant Vice-President performs the following responsibilities:

1. Administers and supervises academic support units including, but not limited to, the University Library, the Learning Center, the Academic Advising Center, and the Media Center.
2. Administers and supervises non-departmental academic programs and services including, but not limited to, the Women's Center and the Center for Connecticut Studies.
3. Coordinates the process of allocating and monitoring the Academic Affairs budget.
4. Serves as the Vice-President's designee in coordinating selected aspects of administrative operations within the Office of Academic Affairs and between Academic Affairs and other campus units and committees.

QUALIFICATIONS:

Terminal degree and substantial experience in higher education administration.

10/8/86

INDEX

President's Office . . . . .	1	V.P. for Administrative Affairs . . . . .	14
Executive Dean . . . . .	2	Associate Dean of Admin. Affairs . . . . .	15
Dean of Personnel Administration . . . . .	3	Director of Fiscal Affairs . . . . .	16
Director of Development . . . . .	4	Director of Computer & Info. Systems . . . . .	17
Director of Athletics . . . . .	5	Director of Plant Maintenance . . . . .	18
V.P. for Academic Affairs . . . . .	6	Dean of Student Affairs . . . . .	19
Assoc. V.P. for Academic Affairs . . . . .	6a	Director of Student Center . . . . .	20
Dean of Continuing Education . . . . .	7	Director of Financial Aid & Vet. Affairs . . . . .	21
Dean of Arts & Sciences . . . . .	8	Director of Institutional Safety . . . . .	22
Dean of Professional Studies . . . . .	9	Director of Housing and Aux. Services . . . . .	23
Director of Library Services . . . . .	10	Director of Career Planning & Placement . . . . .	24
Director of Admissions & Records . . . . .	11	Campus Physician . . . . .	25
Director of Learning Center . . . . .	12		
Director of Media Services . . . . .	13		

VICE-PRESIDENT FOR ACADEMIC AFFAIRS

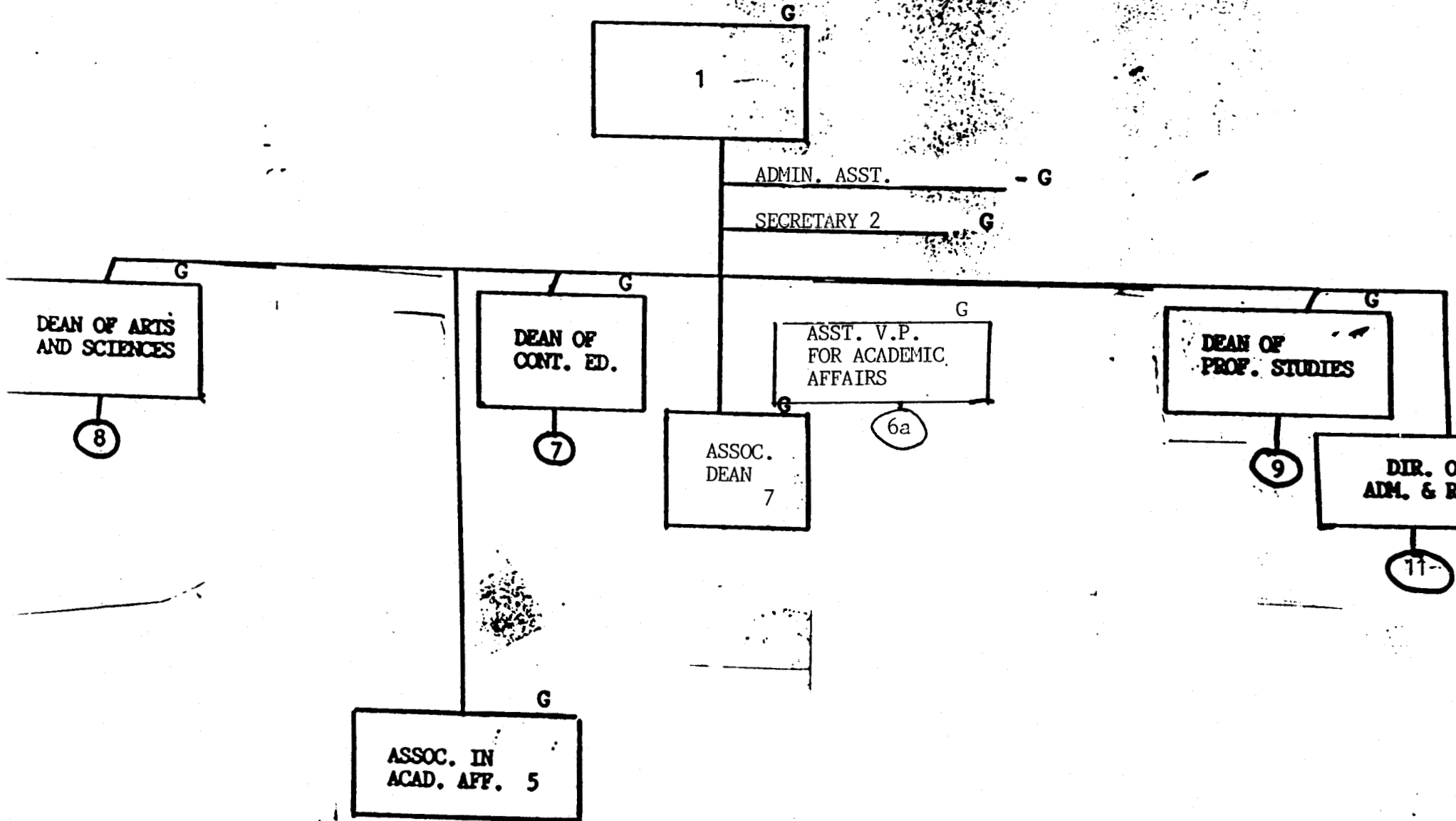

ASSISTANT VICE-PRESIDENT FOR ACADEMIC AFFAIRS

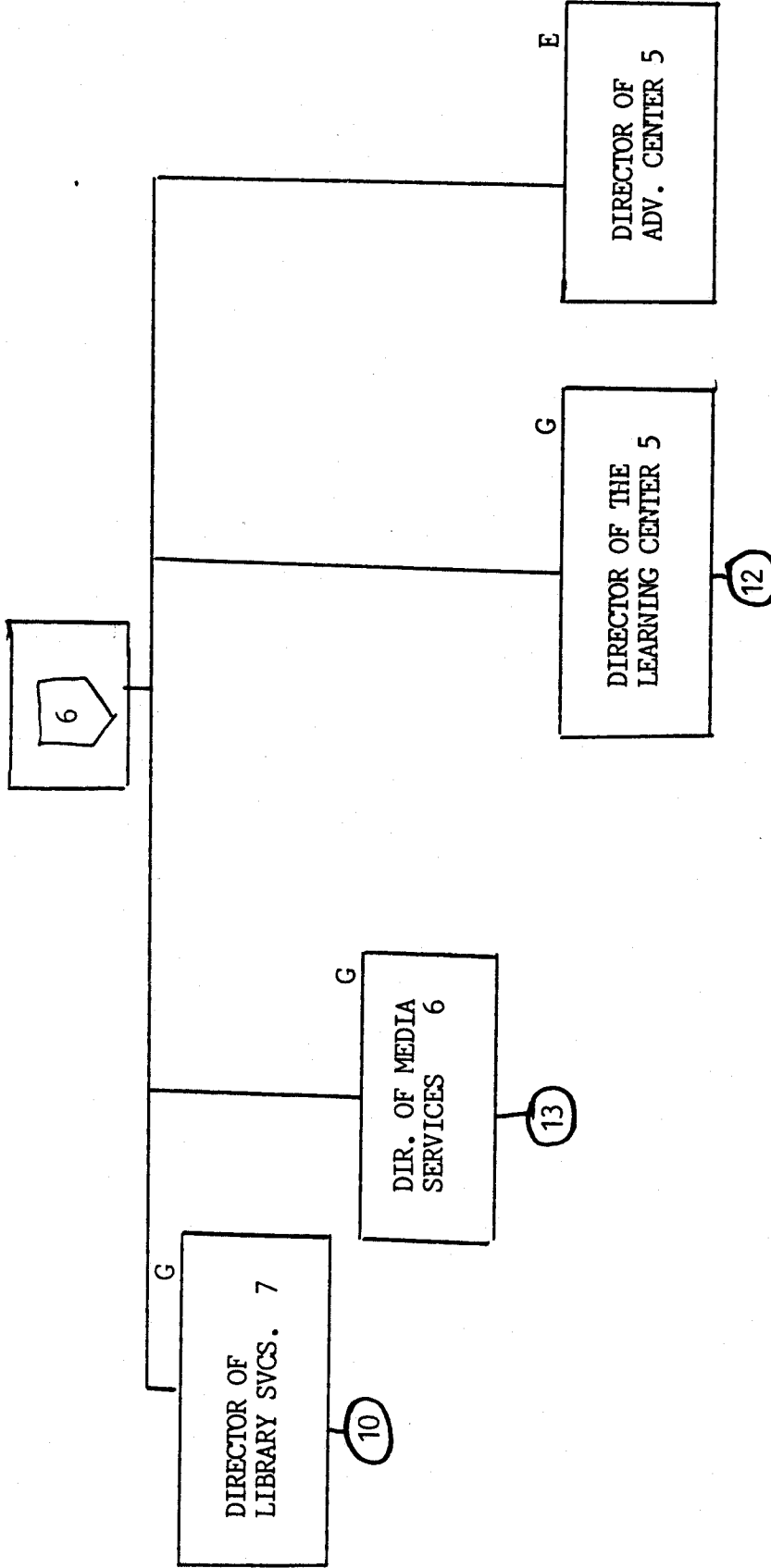

DIRECTOR OF LIBRARY SERVICES

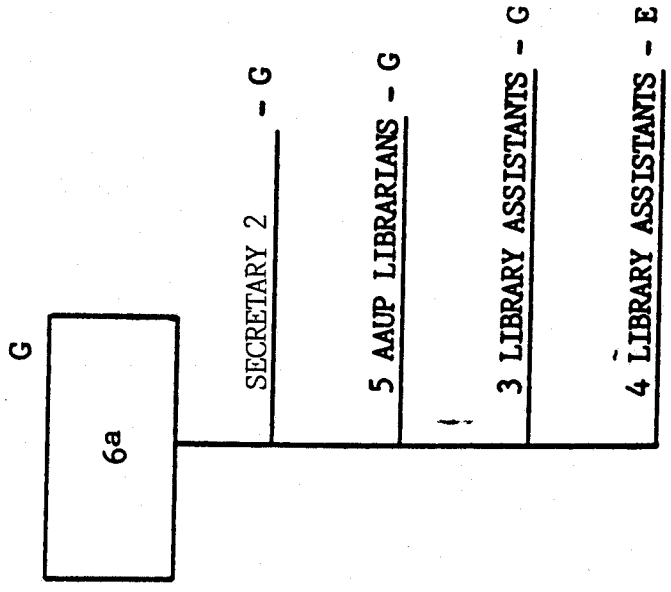

DIRECTOR OF LEARNING CENTER

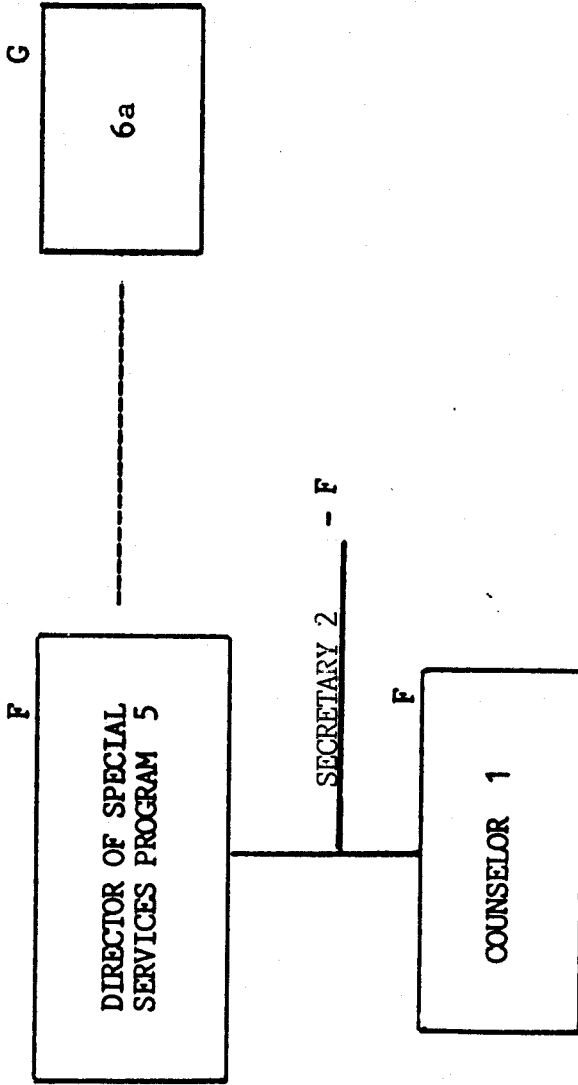



DIRECTOR OF MEDIA SERVICES

